

SCENARIOS, PHASES, ROLES AND DISCOURSES OF INTERNET VIOLENCE IN A HIGHER EDUCATION INSTITUTION

(Escenarios, fases, roles y discursos de la violencia internauta en una institución de educación superior)

Francisco Espinoza Morales

fespinoz@navojoa.uson.mx
<https://orcid.org/0000-00024252-5893>
Universidad de Sonora, México

Jorge Hernández Valdés

jorheval@unam.mx
<https://orcid.org/0000-0001-6490-0479>
Universidad Nacional Autónoma de México, México

Arturo Sánchez Sánchez

arturo.sanchez.s@uatx.mx
<https://orcid.org/0000-0002-4946-1559>
Universidad Autónoma de Tlaxcala,
México

Cruz García Lirios

garcialirios@uaem.mx
<https://orcid.org/0000-0002-9364-6796>
Universidad Autónoma del Estado de Morelos, México



ABSTRACT. From the review of the theories of the cycle of violence, gender violence and the social construction of male and female identities, a non-experimental, exploratory and descriptive study was carried out with a nonrandom selection of students of a public university with the aim to establish a balance and a prospective expectation of violence. Theoretically it is based on the contributions of Mejía, Quezada & García (2018); Mendoza, Carreon, Mejía & García (2017); and Molina, Llamas & García (2018), mainly. The results show that the synaptic weights are explained by incoming, and outgoing latent layers on the pre-contemplation of violence, contemplation of aggressive relationships and personal change. Lines alluding to the kind of relationship research, negotiation and consensus decision making to warn couple conflicts.

Keywords: aggression, couple, knowledge, networks, synapse, violence.

RESUMEN. Desde la revisión de las teorías del ciclo de violencia, la violencia de género y la construcción social de las identidades masculinas y femeninas, se realizó un estudio no experimental, exploratorio y descriptivo con una selección no aleatoria de estudiantes de una universidad pública con el objetivo de establecer un equilibrio y una prospectiva de las expectativas de violencia. Teóricamente se basa en los aportes de Mejía, Quezada & García (2018); Mendoza, Carreon, Mejía & García (2017); y Molina, Llamas & García (2018), principalmente. Los resultados muestran que los pesos sinápticos se explican por las capas latentes entrantes y salientes en la contemplación previa de la violencia, la contemplación de relaciones agresivas y el cambio personal. Líneas que aluden al tipo de relación de investigación, negociación y toma de decisiones por consenso para advertir conflictos de pareja.

Palabras clave: agresión, conocimiento, pareja, redes, sinapsis, violencia.

Recibido: 28/08/2019

Aceptado: 09/03/2020

Espinoza Morales, F.; Sánchez Sánchez, A.; Hernández Valdés, J. & García Lirios, C. (2020). Scenarios, phases, roles and discourses of internet violence in a higher education institution. *SUMMA. Revista disciplinaria en ciencias económicas y sociales*, 2(1), 65-82.

1. Introduction.

The aim of this study is to interpret the knowledge networks of students regarding dating violence, marital therapy and expectation of the relationship. Violence against women is a phenomenon that occurs in developed, emerging or poor latitudes. Psychological studies of violence in general and domestic violence in particular show that these are carried out at any time, circumstance or relationship (Bejar, 2006).

According to the reports of the Organization for Economic Cooperation and Development (OECD), the prevailing violence against women is femicide, domestic work and machismo (male chauvinism). It is about developed dimensions related to society, but it is also possible to observe in developing economies and poor (Harmer, 2001).

It is estimated that every 35 hours on average a woman dies victim of any of the three dimensions of the violence generated against them. Up to 80% of cases, crimes committed in the home of the victim and the perpetrators are former partners between 30 and 45 years rank high incidence and risk. Cases where the femicide acted with deliberation and premeditation advantage represent more than 90% and 64% maintained a conjugal relationship with children (Cenlerwall, 2000). Therefore, the problem of violence against women is focused on the killings carried out by their partners, into his home and after five years of marriage (Entel, 2004).

This means that feticide can be explained from the theory of dating violence according to which, after a period of coexistence that may have been in courtship or in the early years of shared life, -tensions build up, anxiety, fear- that lead to aggression, helplessness, fear, pain, embarrassment and a -ambivalence distance, illusion, hope- continues with a reconciliation phase and restart the cycle with new more and significant determinants of further attacks and tensions (Carreon, Garcia, Quezada, Perez & Mejia, 2017).

However, the theory of intimate partner violence only explained in general terms the vicious circle between two people who are not always related to female identity. In this sense, the theory of gender

violence explained in more detail aggression towards women, because it raises levels of aggression ranging from comments to injury (Carreon, Hernandez, Morales, Rivera & Garcia, 2013).

At the first level, the theory of gender violence proposes the study of the objectification of women which is to highlight physical attributes of the female gender identity regarding masculine identity, but ignores other merits or talents of the person reified. Although the theory of sexual objectification focuses on the female body, ignores the social determinants gender violence, since the construction of human aesthetic is a set of symbols and meanings of social and historical order which was further developed in some latitudes than in others (González & Santana, 2001).

Therefore, in the second level relative to psychological abuse, the theory of gender violence holds that comparisons of the mature body with respect to the young body indicate a systematic strategy of ridiculing the purpose of committing a breach of trust, sexual or economic (Hirigoyen, 2006).

Finally on the third level of the emerging aggression and systematic abuse it is a conditioning by the person committing the crime, as the blows and insults are understood by the victim as a punishment for their actions or lack thereof. At this level, social determinants such as machismo are invisible because it is considered that aggression is a punishment for misconduct or lack thereof (Lameiras, 2004).

The theory of gender violence and the theory of sexual objectification explain the three levels of aggression perpetrators regarding female identity, but shortchange historical and social factors from which is possible to explain the construction of violence against women (Gutiérrez, 2010).

The theory of social gender violence intends to address the issue of violence against women from the socialization of female and male roles. The difference between the two roles is a consequence of the value of male attributes regarding the devaluation of women when it does not have the physical and sexual attributes demanded by the male identity (Loizaga, 2008).

Therefore, sexism and machismo have been identified as two socio - historical factors that explain not only differences between the genders, but also the systematic violence between male identities to female identity (Lopez, 2005). The theory of the culture of violence suggests that companies are of aggressive and abusive nature because they are in a competition for control of resources around which women have felt comfortable with the care and maintenance of the competitor man and manager of the resources (Lopez, 2002).

In this sense, the theory of sexism in general and in particular theory of ambivalent sexism, emphasize the importance that the role of women would have on the competitive education and training of leaders. It is a process in which care, affection and service women are oriented to the formation of male capabilities for command, control and / or monitoring (Lopez, 2002).

Thus, leadership theory explains the formation of decision makers seeking to maximize profits and reduce losses whenever there is a culture of violence where the logic of violence is legitimized as an ideology of success and the use of aggression as an instrument of power (García, Sandoval & Aguilar, 2016). The theory of social gender violence explained in greater depth and detail aggression and historical and systematic abuses of male identity on female identity (García, Carreon & Hernandez, 2016a).

If gender identity is the result of a categorization of attributes and a choice of belonging to a group in power, then the theory of social gender violence stands as the focus of discussion to the ideology that values the masculine attributes and devalues women's when they do not mean a sexual object (Mejía, Carreon & Garcia, 2016).

In academia, we can see the reflection of the problem of violence against women. From knowledge networks, it is possible to investigate not only the differences between the genders, but also the theoretical postulates put forward in order to anticipate the cycles of violence and designing a prevention model in groups that are on the verge of life shared and therefore exposed to the cycle of violence (Carreón, García, Vilchis, Martínez, Sánchez & Quintana, 2016).

The instruments that measure the phenomenon of violence have been constructed from an individual, inter-individual or group approach where self-control, frustration or scarcity of resources are highlighted as determinants of violent actions (Garcia, 2015a). The Self-Control Scale (SCS-16) ponders the perceptual and dispositional dimensions against or in favor of violence. It is about aversion and the propensity to violent lifestyles, although recent research has shown an ambivalence that would explain why individuals with high self-control can move towards a state of unprecedented violence in their personal history.

It is a latent violence that for the SCS-16 turns out to be the greatest contribution of the individualist perspective, although it is known that frustration is a forerunner of violence and it is generated in the interrelation between people which suggests a level of interpersonal analysis. The Scale of Interpersonal Frustration (SIF-21) measures the relations of violence that occur in asymmetric people in which the power of decision-making is concentrated in a single pole, although its dimensions refer to harassment, stalking or the discredit as a result of a goal not achieved or a task not executed.

Low self-control and high frustration in situations of scarcity of common goods such as energy or water anticipates a spiral of violence or struggle for resources. This phenomenon has been known as State violence in which a regime of government, governmental form or political system exerts its power of coercion to reduce the differences of civil strife (Garcia, Carreon, Hernandez & Mendez, 2013).

The Political Authoritarianism Scale (PAS-28) measures the propensity of a state leader to exercise his capacity for initiative, decision and coercion towards sectors hostile to the government regime, public policies, supply strategies or resource distribution programs. However, the SCS-16, the SIF-21 and the PAS-28 do not distinguish between the violence that is exerted towards a specific sector of society from different social sectors such as gender violence.

The instruments that measure gender-based violence focus on the choice of situations of risk, prospective decision and loyalty as predictors of a violent relationship (Garcia, 2015b).

The Ambivalent Sexism Slave (SAS-12) raises beliefs, intentions and behaviors that orient and exacerbate gender differences, particularly measures violence against a vulnerable female sector, but discards a spiral of violence considering that ambivalent sexism is the maximum degree of violence that can be exercised towards a vulnerable sector...

Some alternative proposals to the SAS-12 complement the dimensions and social scenarios in which not only a spiral of violence but of learning is exercised. Neural network analysis distinguishes between a spiral of deliberate violence from an emergent one, planned from an unforeseen and systematic to a casual one.

Neural networks not only warn the degree of learning of violence by perpetrators, victims and spectators, but also proposes the analysis of the synaptic weight or the speed of learning that is an aggression or a defense (Garcia, Carreon, Hernandez, Mejia & Garcia, 2014).

Neural networks suggest that in any information that describes or explains violence, the parties involved generate schemes to process the data and use them in their speeches about the discussion, agreements and responsibility for violence (Garcia, 2015c).

In the case of gender violence, this suggests the involvement of the parties involved even when no differences or acts of violence are observed, but a scenario prone to the exercise of violence is observed, as is the case of the lack of self-control, frustration or lack of common resources (Carreon, Cruz & Santos, 2015).

This is the case of the Institutions of Higher Education (HEI) that are distinguished for being scenarios of information dissemination in digital networks and through technologies and electronic devices (Carreon, Hernandez, Morales & Garcia, 2013). The violence that is observed in electronic social networks such as Facebook, Twitter, Instagram, YouTube, WhatsApp, Periscope or Snap Chat consists of stalking, stashing, bullying and sexting, as well as the risks of identity theft or impersonation.

Universities are dissemination scenarios because it is in their platforms, connections and networks that all types of violence are

emitted between peers or towards authorities such as teachers and administrators, as well as between these actors and students (Garcia, Carreon, Hernandez, Mejia y Garcia, 2014).

The Scale of Stalking on Facebook (SSF-21) warns three dimensions related to the remote monitoring of the victim, the monitoring through a third person or the direct monitoring of the victim, but when relating to acts of aggression his explanatory power is spurious.

The Twitter Trolling Scale (TTS-18) suggests three dimensions related to the propagation of false information, the diffusion of altered or manipulated images and the communication of phrases attributed to the victims, but the daily occurrence of these expressions seems to counteract the prediction of an aggressor intentionality.

The Inventory of Stashing on Facebook (ISF-16) suggests two dimensions related to the propensity of contacts to ignore the attributes or merits of the victim, but when linked to the intention of attacking a person's values are negative. That is, the greater the awareness, the lesser aggression.

The Bullying Scale on Facebook (BSF-15) suggests three dimensions related to the expectation, the incitement and the harassment, although none seems to be related to an aggressive and systematic behavior of a perpetuating power for a probable victim. The Sexting Scale on WhatsApp (SSW-12) suggests two factors linked to the dissemination and reception of unwanted images, but its predictive power of systematic, continuous and planned violence is close to zero.

Therefore, the SSF-21, TTS-18, ISF-16, BSF-15 and SSW-12 can be agglutinated in the analysis of neural networks to observe the interrelation between stalking, stashing, trolling, bullying and sexting since the technique allows to observe in different moments the degree of learning of each violent pathology according to the informative reagents or available stimulative items (Carreón, Hernandez, Morales, Garcia & Bustos, 2014).

However, the reliability and validity of the scales reviewed has not been demonstrated in probabilistic sampling, so work is being

carried out on content validity based on the qualitative analysis of the concepts included in the instruments, as well as the assurance that these are words that are understandable to the study samples (García, Carreon & Hemandez, 2016b).

2. Method.

By virtue of the fact that discourse analysis centers its interest on the understanding of the meaning of a positioning, the technique of neural networks unveils the symbolism of violence turns out to be pertinent since from the interrelation between stalking, trolling, stashing, bullying and sexting it will be possible to observe a resultant synaptic learning as a perpetrator, victim or potential spectator.

The relationship between stalking and trolling suggests a synaptic learning that would reveal itself in stalking discourses oriented towards provocation. It is a degree of systemic violence in which the perpetrator seeks to reverse his role with that of the victim so that the victim appears as the aggressor and the perpetrator is exempted from all responsibility. Consecutively, the link between trolling and stashing suggests that the potential aggressor seeks to provoke the victim's ignorance in order to exclude himself from the asymmetric relationship and position the victim as a person unconcerned with his safety.

The association between stashing and bullying denotes not only a scenario of ignorance of violence, but of ridicule at a distance or hidden in such a way that it is imperceptible by the victim, again exempting the aggressor from all responsibility. The correlation between bullying and sexting connotes a potential perpetrator strategy based on the ridicule of sexual preferences or identities of potential victims, although not necessarily the diffusion of attributes would be linked to explicit contents of the sexuality of a potential victim.

The analysis of discourses can be relevant to reveal stalking, trolling, stashing, bullying and sexting, although a direct approach to these narratives involves the risk of inferring meanings of victimization or relative to exempt the responsibility of the perpetrator. This is how the Delphi technique allows to infer the meanings of discourses from

contextual, comparative and integral filters in order to observe differences between the types of violence, as well as their interrelations oriented to a spiral of violence.

The Delphi technique is distinguished by its comparative structure of information, processing, inference and integration of meanings, although if the actors are considered; perpetrators, victims and bystanders or instigators, the theme assumes phases; pre contemplation, complacency, planning, perpetration and systematization of violence.

A non - experimental, exploratory and interpretative study was conducted. A non - probabilistic and intentional selection of 15 students whose parents are separated and 15 women whose parents are together.

Matrix discourse analysis related to intimate partner violence, marriage counseling and social change. They conducted interviews in the department of psychology at the public university. Participants are guaranteed the confidentiality of information and were informed that the results of the study would not directly or indirectly affect their academic status as it only sought to investigate some related to the experience of living with parents speeches separately or together. The information was processed in the Analysis Package Neural Networks.

It is a technique to estimate the inputs or requests for information and its relationship with the outputs of information or knowledge. It consists of a flexible structure that predicts the knowledge around a topic considering the entry of relevant information. The graph of the neural network includes a balance of entries and information processing, as well as a prospective decision based on the differences found. Synaptic weights are storing information and knowledge learned.

It is a technique that is part of the neural network analysis and is used to calculate the relationship between inputs and outputs information. The results shown the technique can be a freed forward architecture where unidirectional connections prevail without feedback. The layers resulting from the estimation are; 1) input layers or predictors; 2) hidden layer or unobservable or latent nodes; 3) output layer or prospective- -knowledge expected responses.

3. Results.

Three Layers of input factors relating to group membership, couple therapy and partner relationship, latent and prospective - expectations change the relationship, the spouse change or change staff- (see Table 1).

Table 1. Structure of the knowledge network.

<i>Input layer</i>	<i>Factors</i>	<i>1</i>	<i>Group</i>	
			2	Relationship
			3	Therapy
	Number of units		twenty	
<i>hidden layers</i>	Number of hidden layers		1	
	Number of units in the hidden layer 1		10	
	Activation function		hyperbolic tangent	
<i>Output layer</i>	dependent variables	1	Expectation	
	Number of units		5	
	Activation function		Softmax	
	Error function		cross entropy	
<i>to. Unit bias excluded</i>				

Source: elaborated with data from the study (2020).

We can see that the latent layer with 10 units or nodes of hidden knowledge reflects the impact of perceptions about the marital relationship of parents, relations of intimate partner violence and couple therapy required. The output layers show expectations about marital relations violent (synaptic weight = 0.320). That is, the sample of students, from parental groups to which they belong, the relations of partner violence perceived and required therapies seem to set a prospective differently and less than the perceived violence. Such findings support the structure of the knowledge network in which 50% of the weighted synapse is explained by the relationship between pre contemplation, contemplation and action of personal change (see Table 2).

Table 2. Structure of knowledge of the prospective violence.

<i>Ex am ple</i>	<i>Obse rved</i>	<i>Predicted</i>					
		Pre con te m plati on	Con te m plati on	Pre p arati on	A c ti o n	Main ten ance	corr ect per cent age
<i>Tr ain ing</i>	Pre con te m plati on	1	3	1	0	0	20,0 %
	con te m plati on	2	3	0	1	0	50,0 %
	Pre p arati on	0	0	1	1	1	33,3 %
	Acti on	1	4	1	1	0	14,3 %
	Main ten ance	0	1	1	0	0	0,0 %
	over al per cent age	17,4%	47,8%	17,4 %	1 3, 0 %	4,3%	26,1 %
<i>Te sts</i>	pre con te m plati on	0	0	0	0	0	0,0 %
	con te m plati on	0	1	0	1	0	50,0 %
	pre p arati on	0	0	0	0	0	0,0 %
	Acti on	0	0	1	0	0	0,0 %
	main ten ance	0	1	2	0	1	25,0 %
	over al per cent age	0,0%	28,6%	42,9 %	1 4, 3 %	14,3 %	28,6 %
<i>Dependent variable: Expectation</i>							

Source: elaborated with data from the study (2020).

The neural network (multilayer perceptron) shows higher percentages of synaptic weight in the complacency that explains the

degree of expectation of stalking, trolling, stashing, bullying and sexting. This is so because the participants seem to focus their discourse on their positioning as spectators rather than as perpetrators and victims. More important is to note that learning seems to focus on expectation rather than on victimization or perpetration in the participants interviewed.

Planning is an instance that suggests a probable intentionality to carry out a violent action or at least to execute an aggression that in the case of the informants seems to focus on future violence and the interrelationships between the learning of the continuous phases with what was planned.

Once the synaptic weights of learning about the roles around violence were established, we proceeded to observe the structure of trajectories between the established factors in order to anticipate possible learning scenarios, as well as to predict probable routes of apprehension of the meaning of the violence, considering the interrelation between the actors; perpetrators, victims and spectators (see Figure 1).

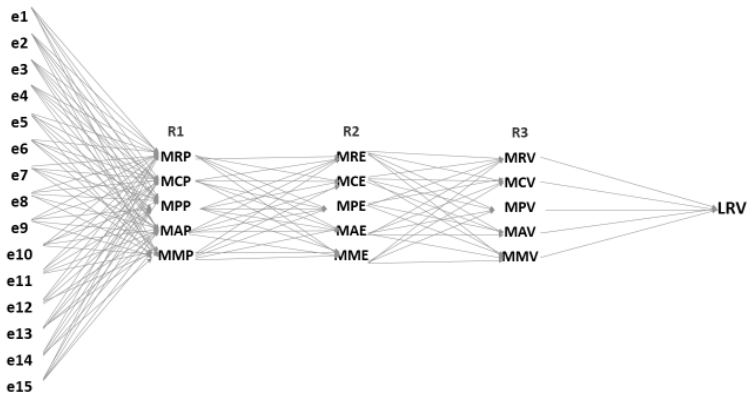

e = extract from the discourses on violence, R = Round; MR = Means Precontemplation, MC = Means Contemplation, MP = Means Planification, MA = Means Action, MM = Means Maintenance: P = Perpetrator, E = Expectant, V = Victim; LRV = Learning a rol in the face of violence

Figure 1. Neural networks (Multilayer Perceptron) of the learned meaning of violence.

Source: Elaborated with data study (2020).

The structure of relations between excerpts from the discourse of violence with respect to the constructions of the meanings between pre-contemplation, contemplation, planning, action and the systematization of violence suggests a building on the learning of violence between the phases and the actors involved.

The construction of the meaning of violence in the interviewees seems to be carried out from the roles learned and the assimilated phases of the violence, although the learning of a specific role will depend on other interactions with experiences and situations that reduce or increase the degree of learning the violence.

4. Discussion.

The contribution of this study lies in the weighing of a stock of knowledge and the prospect of making personnel decisions to change the perceived problem. However, the state of knowledge and current literature have established that gender identity is determinative of mate selection, shared life and couples therapy.

It was found in the present study that the knowledge network of partner violence lies in three phases on the pre contemplation, contemplation and personal change. This means that the identity of the survey sample consists of a network of information that affects the decision to change from the recognition of situations of violence and expectations of relationships without violence.

Psychological studies of intimate partner violence show that when the relationship is perceived as a formal one, decisions are negotiated and agreed, but when the relationship is assumed to be superfluous, then decisions are delegated to the couple. Molina, Llamas & Garcia (2018) demonstrated that Internet harassment is linked to learning the roles of perpetrator and victim. It is a risk aversion that would be linked to the learning of potential victims of violence on the Internet and the propensity to risk associated with a potential perpetration of violence in electronic networks.

In the present work, the interrelation between the discourses that reveal the positioning of spectators was greater than that of potential victims and perpetrators, suggesting a learning centered on information related to testimonies, experiences or events that distance the informant from the other actors, but that reveals a legitimization, recreation and apology of violence.

Mejía, Quezada & García (2018) focused their attention on the re-adaptation as a result of the convergence between negotiations, commitment and responsibilities built between perpetrators of violence and police actors, although in the present work the concept of re-adaptation was not observed it is possible to warn that the follow-up of the cases would be the most likely factor for the interviewed participants since their meaning of expectation seems to be related to the surveillance of the violence.

Mendoza, Carreon, Mejía & García (2017) observed a systemic violence of the state for potential victims of the suppression of public services and care for the elderly. They distinguished between the perpetration of violence against old age and violence against family members who depend on the service of public isolation in order to investigate the pathologies that arise when this right is suppressed by the beneficiaries.

In the present work, the systemic violence of the State can be related to the ascription that the informants carry out for the role of spectators. The advocacy of crime and violence that the official media carry out can result in a high level of audience and expectation Future research concerning decisions partner should corroborate the findings of this study to deepen the type of relationship to conflict resolution. In this sense, the learning of a perpetrator, victimizer or expectation of violence role will depend on other situations, scenarios or experiences of the interviewees, although it will also be pertinent to observe the phases of the violence; pre-contemplative, contemplative, planned, active and systematic in relation to the availability of resources and the rule of law, public security action, the delivery of justice and the readjustment.

In this way, the technique of neural networks, multilayer perceptron and synaptic weight combined with the technique of inferential analysis of the Delphi meaning in its analysis rounds allows to reveal the constructed meaning of the violence before multiple phases, scanners and actors.

The applicability of neural networks in public safety policies lies in the explanation and anticipation of the emergence of multiple roles in a situation or event of risk, as well as in the observation of scenarios prone to the spiral of violence, but above all learning a role regardless of the psychological background of those involved.

In higher education institutions, the implementation of programs and strategies to prevent violence, as well as the promotion of risk-free lifestyles, implies neural networks that notice the spiral of violence and not only the absence or diminution of self-control or Increased frustration

The intervention of social work in universities suggests a diagnosis of neural networks, as well as the assimilation of a meaning around the scenarios, phases and roles of violence.

It is a follow-up to the cases of low self-control, high frustration and relative scarcity of resources moderators of violence in the electronic networks and the emergence of new roles in Facebook, Twitter, SnapChat, WhatsApp, YouTube or Periscope. Because these technologies advance rapidly, the roles tend to merge and the resulting ambivalence involves more sophisticated analysis techniques such as the mining of opinions, texts and data that offer a comprehensive perspective of the risk scenario. Therefore, strategic actions to prevent the apology of violence, as well as to resignify roles and learn new risk-free forms of interaction will be essential factors for the intervention of social work.

5. Conclusions.

The objective of this paper was to reveal the meaning of violence in key informants that were ascribed and positioned in a narrative of expectation rather than perpetration or victimization,

although the design of the research limits the findings to the interview scenario, suggesting the extension of the work to the symbols of apology and legitimization of the violence diffused in the media of communication.

In relation to the state of the matter, the investigation of violence on the Internet involves the use of sophisticated analysis techniques that allow us to infer the meaning of the roles, phases and scenario of violence in successive rounds. Regarding the technique of Delphi analysis and neural networks, it will be necessary to compare them with the mining of opinions, texts and data to investigate the differences and similarities in terms of the interpretation of meanings and the positioning of constructions around violence.

Finally, in terms of intervention to prevent or reduce the relationships of violence in universities that are distinguished by access to electronic networks where diseases such as stalking, trolling, stashing, bullying and sexting prevail, it is pertinent to warn learning networks that are gestating to anticipate scenarios with spirals of violence.

Bibliographic references.

- Bejar, B. (2006). Social work and family violence. A professional management proposal. Buenos Aires: Editorial space.
- Carreón, J.; Cruz, P. & Santos, M. (2015). Administration the social fears. Contrast in a model perception of insecurity in Mexico. *Ehquidad*, 4, 31-60.
- Carreón, J.; García, C.; Quezada, A.; Pérez, G. & Mejía, S. (2017). Governance of public security in the building of sociopolitical identity. *Psychology*, 6(12), 32-52.
- Carreón, J.; García, C.; Vilchis, F.; Martínez, J.; Sánchez, R. & Quintana, L. (2016). Reliability and validity of instrument that measures seven dimensions of security perception in students from a public university. *Psychology*, 12(20), 65-76.
- Carreón, J.; Hernández, J.; Morales, M. & García, C. (2013). Towards the construct of a civil security a public identity sphere. *Eleuthera*, 9(2), 00-115.

- Carreón, J.; Hernandez, J.; Morales, M.; Garcia, C. & Bustos, J. (2014). Contrast of a reliability model of social function of emotions for public safety. *Psicumex*, 4(2), 44-70.
- Carreón, J.; Hernandez, J.; Morales, M.; Rivera, B. & Garcia, C. (2013). Civil and fields áreas around dimensions of safety and violence. *Psychology*, 5(2), 9-18.
- Centerwall, E. (2000). *Love in adolescence: let's talk about sexuality and relationships at school*. Barcelona: Ediciones del Serbal.
- Entel, R. (2004). *Women in situations of domestic violence*. Buenos Aires: Editorial space.
- García, C. (2015a). Reliability and validity of instrument that measures criminal perceptions. *Development & Education*, 34, 25-33.
- García, C. (2015b). Specification a model criminal behavior. *Act of Psychology Research*, 5(2), 2028-2042.
- García, C. (2015c). The sociopolitical legitimacy of the administration of public security in Xilitla, San Luis Potosí (México). *Management Research*, 115(44), 24-40.
- García, C.; Carreón, J. & Hernández, J. (2016a). Governance of terror a crime. *Psychology*, 13(2), 168-185.
- García, C.; Carreón, J. & Hernández, J. (2016b). Public security governance based on ideas of identity and risk perception that have been established by the media within the citizen agenda. *Rumbos*, 11(13), 103-116.
- García, C.; Carreón, J.; Hernandez, J. & Mendez, A. (2013). Systems of sociopolitical violence. *Polis*, 12(36), 343-365.
- García, C.; Carreón, J.; Hernandez, J.; Mejía, S. & Garcia, E. (2014). Identidad sociopolítica delictiva en Mexico. *Psychology*, 14(1), 5-16.
- García, C.; Sandoval, F. & Aguilar, J. (2016). Approach to the framed of the printed media regarding attention to victims of the case Ayotzinapa, Iguala, Guerrero (México). *Secci*, 20(39), 154-161.
- Gonzalez, R. & Santana J. (2001). *Violence young couples. Analysis and prevention*. Madrid: Pyramid.
- Gutiérrez, C. (2010). *Training for teachers and teachers of basic education in comprehensive sexual health. Guide to the coordinator and coordinator. Secondary level. México*.
- Harmer, S. (2001) *Final report outlining the highlights of the Bully Prevention Project Calgary, AB*. Unpublished.

- Hirigoyen,, F. (2006) Battered women. The mechanisms of intimate partner violence. Buenos Aires: Editorial Paidós.
- Lameiras, M. (2004). Agarimos Program. Coeducational program of psycho-affective sexual development Madrid: Pyramid.
- Loizaga, F. (2008) New teaching techniques in sex education Madrid: Editorial Mc Graw-Hill.
- Lopez, A. (2002). Communicative competence, gender identity and teacher training; in Interuniversity Magazine Teacher Training.
- Lopez, F. (2005). The sexual education of children. Madrid: Ediciones Pyramid.
- Mejia, S.; Carreon, J. & Garcia, C. (2016). Psychological effects of violence and insecurity in erderly. *Psychology*, 13(1), 39-55.
- Mejía, S.; Quezada, A. & García, C. (2018). Reliability and validity of instrument that measures the perception of the reahabilitate penitenciary governance. *Psychology*, 7(3), 80-96.
- Mendoza, D.; Carreón, J.; Mejía, S. & García, C. (2017). Especificación de un modelo de representaciones propagandísticas en adultos mayores ante la seguridad pública. *Tlatemoani*, 25, 21-30.
- Molina, H.; Llamas, B. & García, C. (2018). Reliability and validity an instrument that measures perceived harassment on the internet. *Psychology*, 15(2), 225-242.